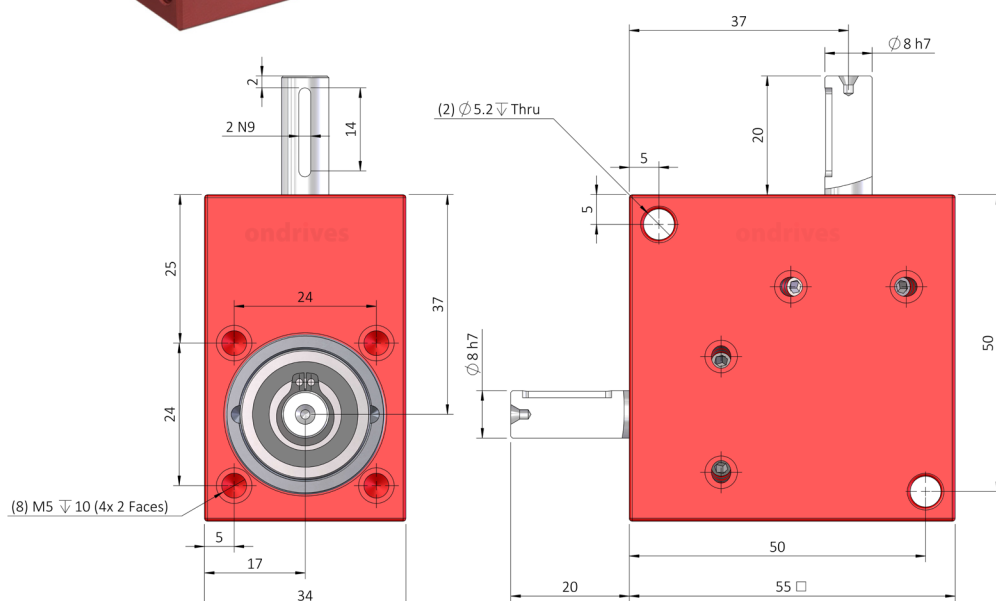
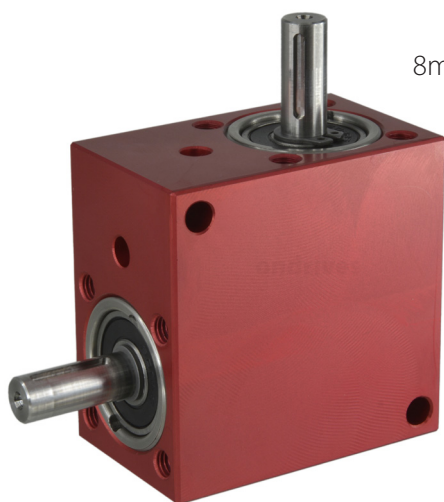

BLH30

# ondrives

Precision Gears

## Spiral Bevel Gearboxes

8mm Input Shaft • 8mm Single Output Shaft •  $T_{2n}$  1.76-2.2Nm **1:1 - 2:1**

Part Numbers					
Output Backlash j	Output Backlash j A	Output Backlash j AR	Gear Ratio i	Efficiency $\eta_z$	Reflected Inertia at Input
$\leq 0.75^\circ$	$\leq 0.50^\circ$	$\leq 0.166^\circ$		$n_{1nom}$	$kg \cdot m^2$
BLH30-1	BLH30-1A	BLH30-1AR	1:1	88%	$2.19 \times 10^{-6}$
BLH30-2	BLH30-2A	BLH30-2AR	2:1	88%	$5.00 \times 10^{-7}$

**Weight:** 0.30 kg.

**Nom. Input Speed** [ $S5 T_2 n$ ]  $n_{1nom}$ : 1,000  $min^{-1}$  (r/min)

**Max. Input Speed**  $n_{1max}$ : 3,000  $min^{-1}$  (r/min)

**Lubrication:** Grease Shell Gadus S2 V220AD 2

**Lubrication Temperature:** Max. Operating  $\approx 60^\circ C$

**Max. Input Radial Load**  $F_{r1}$ : 30N.

**Max. Output Radial Load**  $F_{r2}$ : 30N.

**Max. Input Axial Load**  $F_{a1}$ : 20N.

**Max. Output Axial Load**  $F_{a2}$ : 20N.

Testing in your application is necessary.

You will need to assess duty cycles and confirm suitability with your own calculations.

Figures listed are for guidance only.

Cooling may be needed dependent on application.

**ondrives**  
Precision Gears

T: +44 1246 455500  
sales@ondrives.com www.ondrives.com  
Updated March 2024 subject to change for use as a guide only.

Spiral Bevel Gearbox

### Spiral Bevel Gearboxes

8mm Input Shaft • 8mm Single Output Shaft •  $T_{2n}$  1.76-2.2Nm **1:1 - 2:1**

BLH Series Spiral Bevel Gearbox

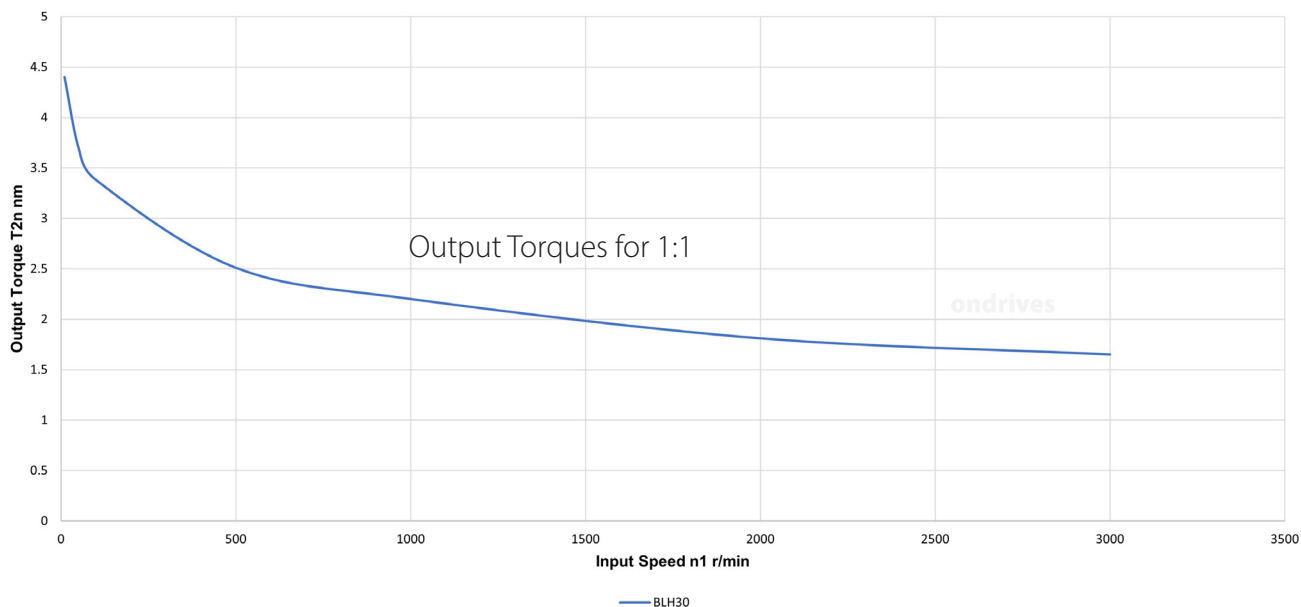

BLH Series Spiral Bevel Gearbox

