

FF30

# ondrives

Precision Gears

Parallel Offset Gear Reducers



## 67.3mm Centres Parallel Offset Gear Reducers

15mm Input Shaft 20mm Output Bore •  $T_{2n}$  21.5Nm – 166Nm **2:1 - 7:1**

**Spur - Helical Gears.**

**Standard Versions - Standard Torque**

Steel Gears, will give you good levels of strength and torque in use.

**XH Versions - High Torque**

Hardened Gears, will give you high levels of strength and torque in use.

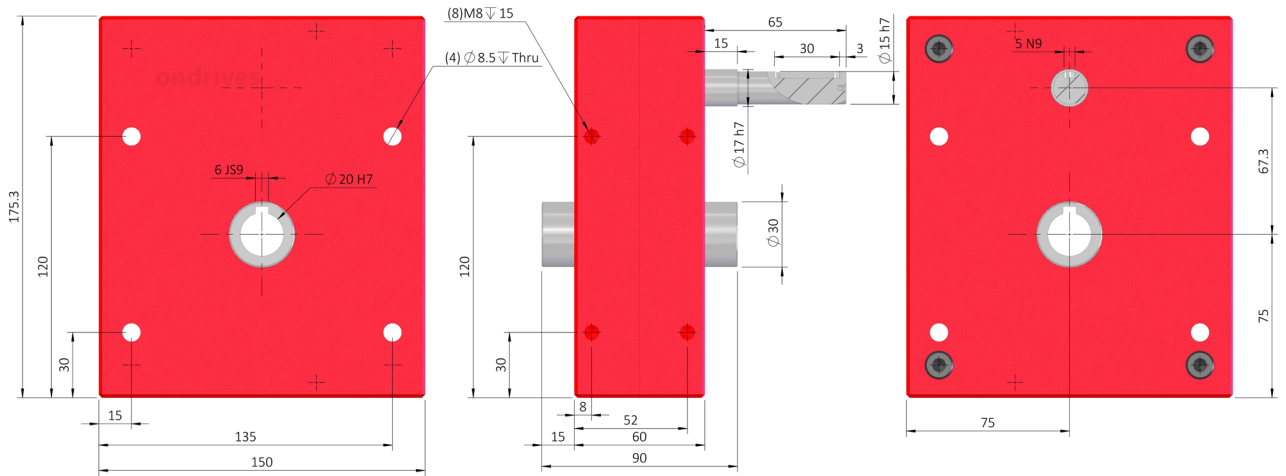

Output Backlash j	Part Numbers		Gear Ratio i	Efficiency $\eta_z$	Torque Version
Output Backlash j	Output Backlash A	Output Backlash AR			
$\leq 0.50^\circ$	$\leq 0.16^\circ$	$\leq 0.08^\circ$		<b>n1nom</b>	
FF30-2	FF30-2A	FF30-2AR	2:1	93%	Std
FF30-3	FF30-3A	FF30-3AR	3:1	93%	Std
FF30-4	FF30-4A	FF30-4AR	4:1	93%	Std
FF30-5	FF30-5A	FF30-5AR	5:1	93%	Std
FF30-6	FF30-6A	FF30-6AR	6:1	93%	Std
FF30-7	FF30-7A	FF30-7AR	7:1	93%	Std
FF30-XH-2	FF30-XH-2A	FF30-XH-2A	2:1	93%	High
FF30-XH-3	FF30-XH-3A	FF30-XH-3A	3:1	93%	High
FF30-XH-4	FF30-XH-4A	FF30-XH-4A	4:1	93%	High
FF30-XH-5	FF30-XH-5A	FF30-XH-5A	5:1	93%	High
FF30-XH-6	FF30-XH-6A	FF30-XH-6A	6:1	93%	High
FF30-XH-7	FF30-XH-7A	FF30-XH-7A	7:1	93%	High

**Weight:** 5.5kg.

**Nom. Input Speed [S5  $T_{2n}$ ] n1nom:** 1,000  $\text{min}^{-1}$  (r/min)

**Max. Input Speed n1max:** 2,000  $\text{min}^{-1}$  (r/min)

**Lubrication:** Grease Shell Gadus S5 V42P 2.5

**Lubrication Temperature:** Max. Operating  $\approx 60^\circ\text{C}$

**Max. Input Radial Load  $F_{r1}$ :** 200N.

**Max. Output Radial Load  $F_{r2}$ :** 600N.

**Max. Output Axial Load  $F_{a2}$ :** 400N.

Testing in your application is necessary.

You will need to assess duty cycles and confirm suitability with your own calculations.

Figures listed are for guidance only.

Cooling may be needed dependent on application.

ondrives

Precision Gears

T: +44 1246 455500

sales@ondrives.com www.ondrives.com

Updated April 2024 subject to change for use as a guide only.

### 67.3mm Centres Parallel Offset Gear Reducers

15mm Input Shaft 20mm Output Bore •  $T_{2n}$  21.5Nm – 166Nm **2:1 - 7:1**

FF30 FFS30 2:1 - 7:1 Series Parallel Offset Gearboxes

